



GENUINE PARTS

INSTALLATION INSTRUCTIONS

DESCRIPTION: Splash Guard Kit
APPLICATION: Versa Sedan (2015)
PART NUMBER: 999J2 43xxx (xxx Designates color)

KIT CONTENTS:			
Item	Qty.	Part Description	Service Part Number
A	1	Splash guard - Front Left	---
B	1	Splash guard - Front Right	---
C	1	Splash guard - Rear Left	---
D	1	Splash guard - Rear Right	---
E	2	Clip (Short)	15-53 10501
F	4	Clip (Long)	11296 AG000
G	2	Spring nut M5 (Long)	08964 1055A
H	4	Spring nut M5 (Short)	12-41 00771
I	4	Tapping screw M5 × 20 (Short)	14-51 00891
J	2	Tapping screw M5 × 25 (Long)	---
K	2	Protection film tape	---
L	1	Installation Instruction Replacement Template	999V2 AW000
M	1	Paper template	---

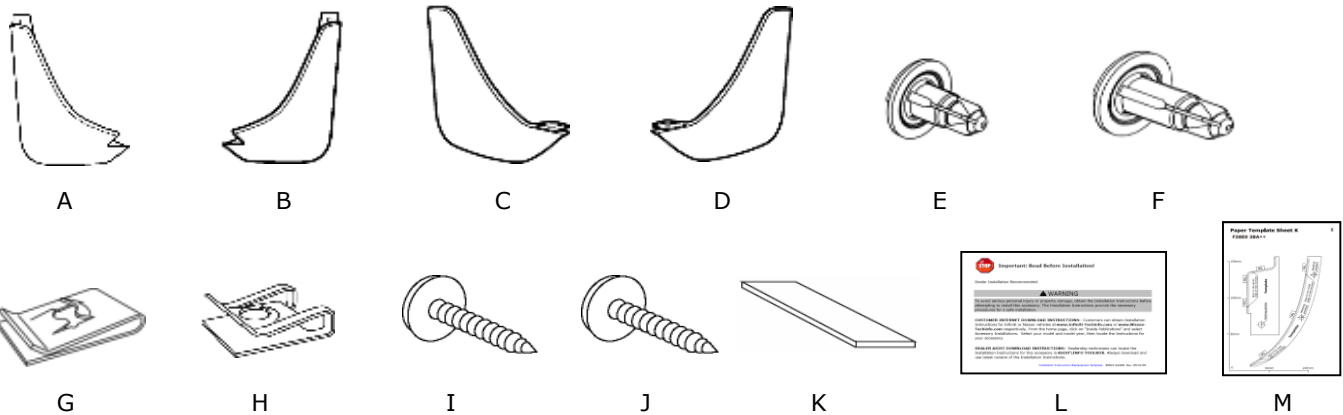

TOOLS REQUIRED:

- Phillips head short screwdriver
- Clip remover
- Drill
- Scissors
- Mild soap / water mixture
- 3 mm (1/8"), 6mm (1/4"), and 8mm (5/16") Drill Bit
- Clean, lint-free wiping cloth
- Center punch / Awl
- Tape

PRE-INSTALLATION WARNINGS, CAUTIONS, CRITICAL STEPS, and NOTES:

- Dealer Installation Recommended.
- These instructions are for left side of vehicle; same procedure applies to right side.
- Jack up vehicle using instructions under "Changing Tire" section of owner's manual.

INSTALLATION PROCEDURE:

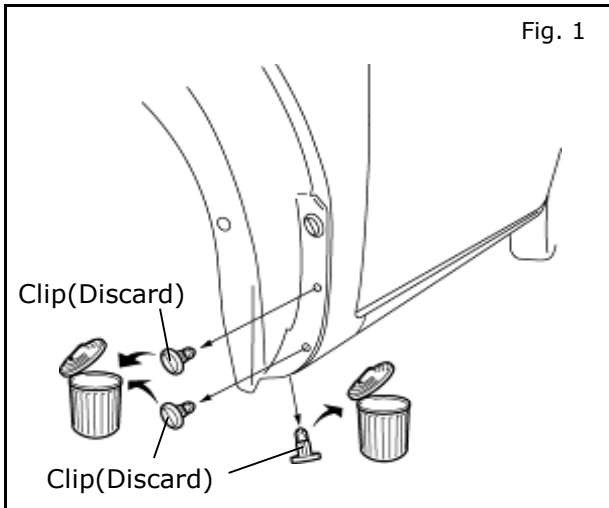

1) Turn tire and remove clips from fender protector.

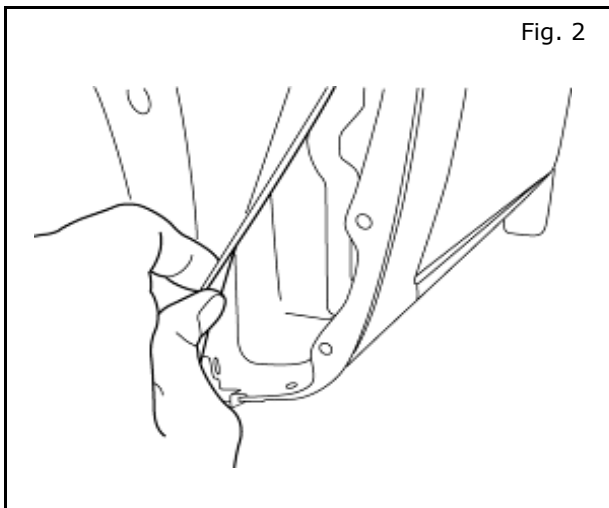

2) Pull fender protector out.

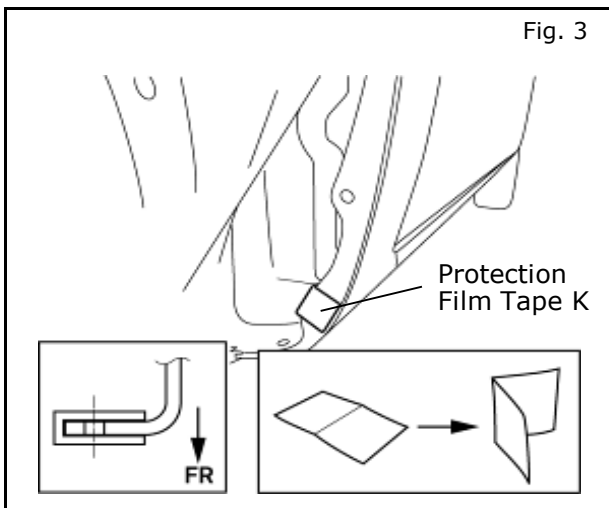

3) Apply protection film tape K to fender flange and fold over back.

INSTALLATION PROCEDURE:

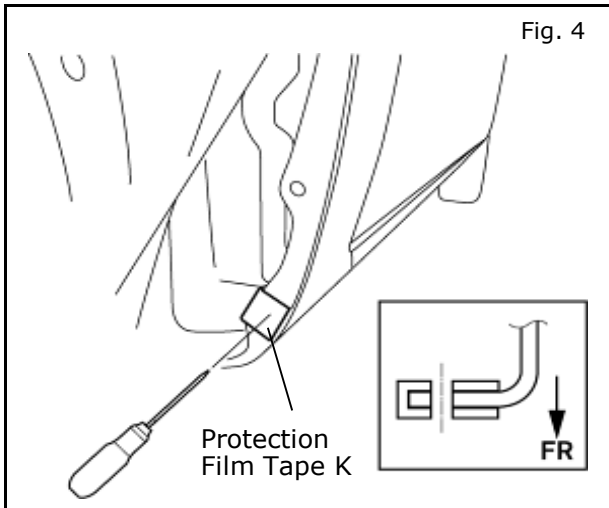

4) Poke hole in protection film tape K.

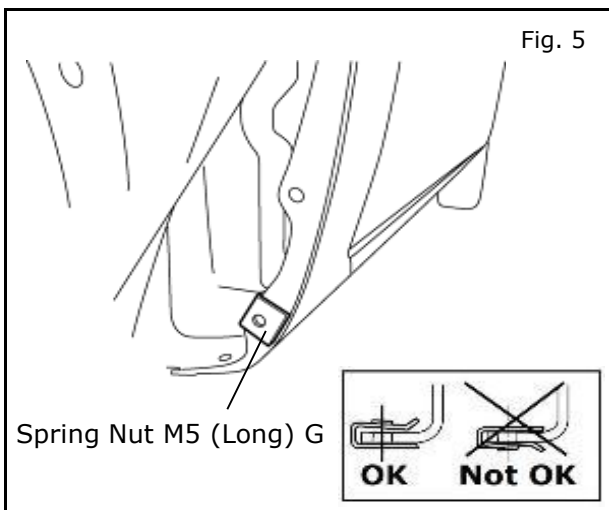

5) Install spring nut M5 (Long) G.

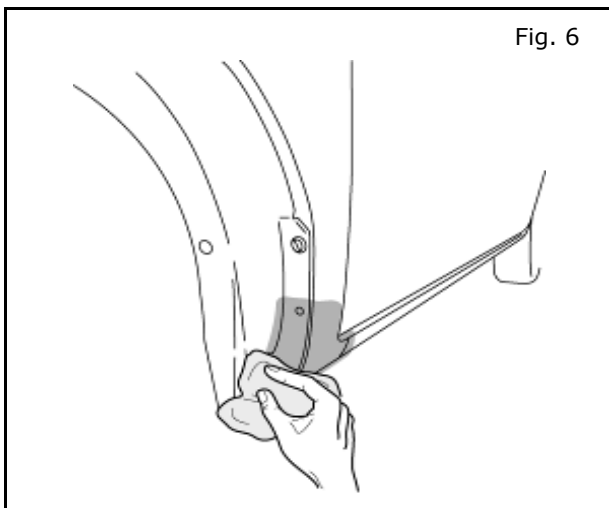

6) Clean installation surface (shaded area) with mild soap/water mixture.

INSTALLATION PROCEDURE:

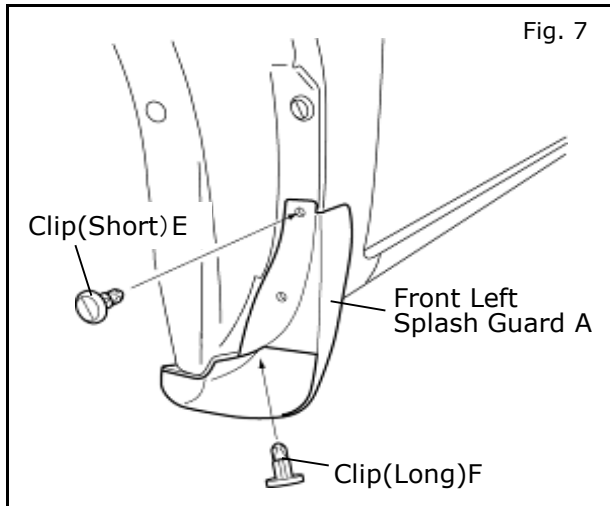

- 7) Align front splash guard to vehicle.
- 8) Install clips E/F.

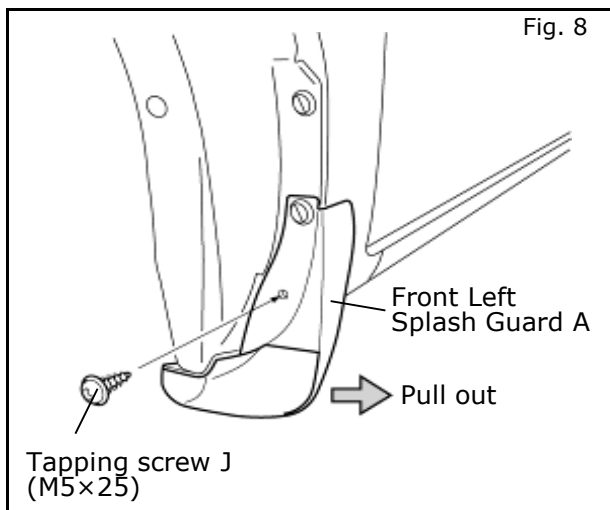

- 9) Pull splash guard out and install tapping screw J.

NOTE:

Pull Splash Guard out while tightening screw to ensure no gap occurs between Fender and Splash Guard.

Do not over tighten screws. Reference Tighten Torque: 3.8~4.4 N-m {34~39 in-lb}

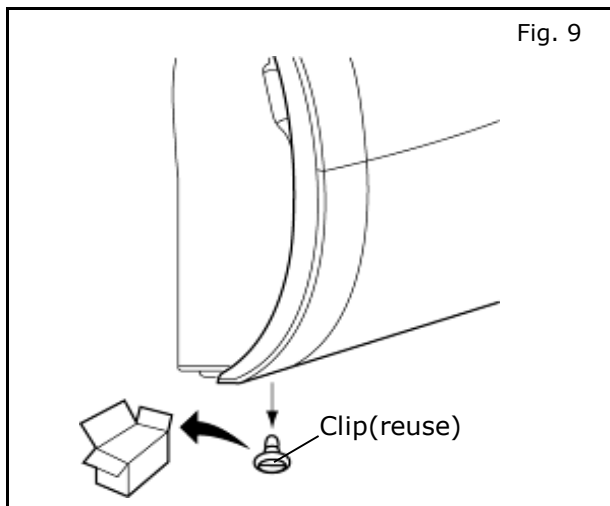

- 10) Remove clip from rear bumper (Keep to reuse).
- 11) Cut out paper template M.

INSTALLATION PROCEDURE:

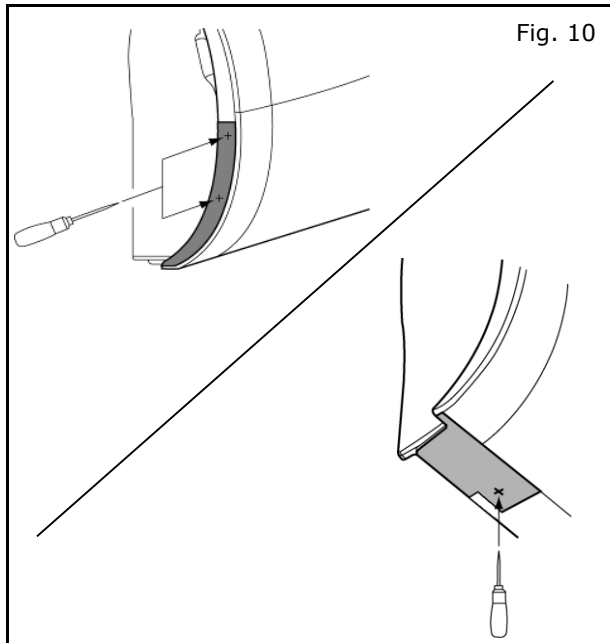

12) Position the paper template M.

- a) Fold tabs of paper template M.
- b) Align paper template M to the rear bumper and apply masking tape to hold the paper template M in place.
- c) Mark the hole position (+) with center punch.
- d) Slowly remove masking tape and paper template M (reuse).

NOTE:

Be sure not to damage the paper template M during removal, as it will be required for right side installation.

- e) Repeat steps a) through c) for right side.

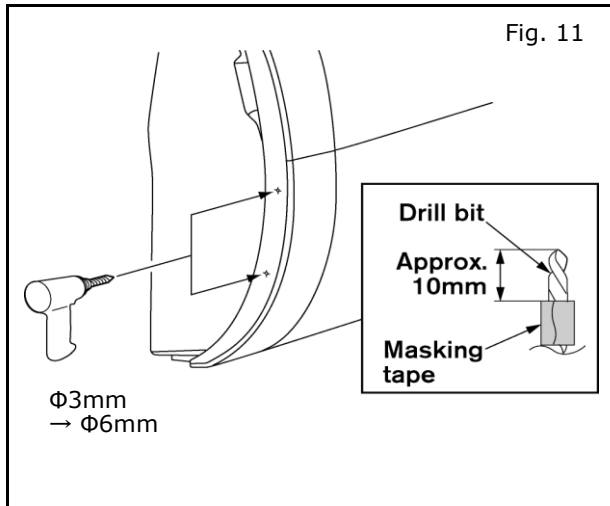

13) Drill 3mm→6mm holes at marked locations.

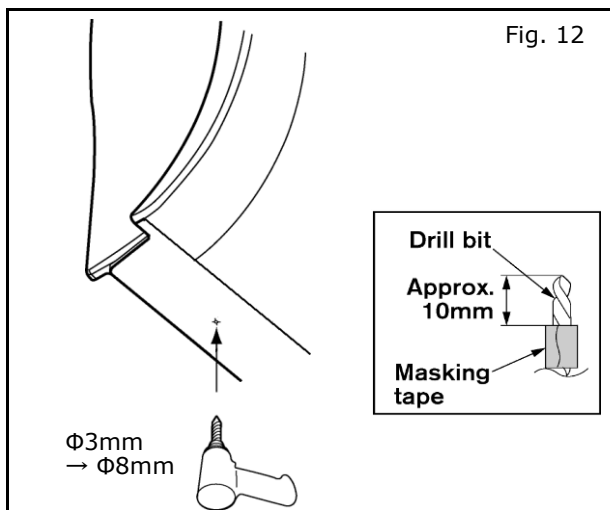

14) Drill 3mm→8mm hole at marked location.

INSTALLATION PROCEDURE:

Fig. 13

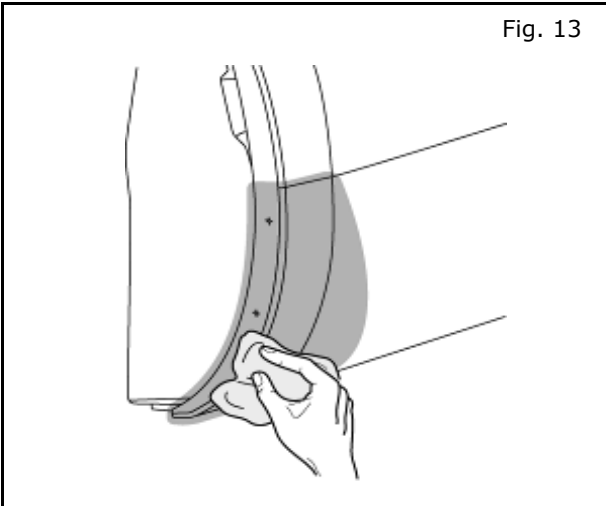

15) Clean installation surface (shaded area) with mild soap/water mixture.

Fig. 14

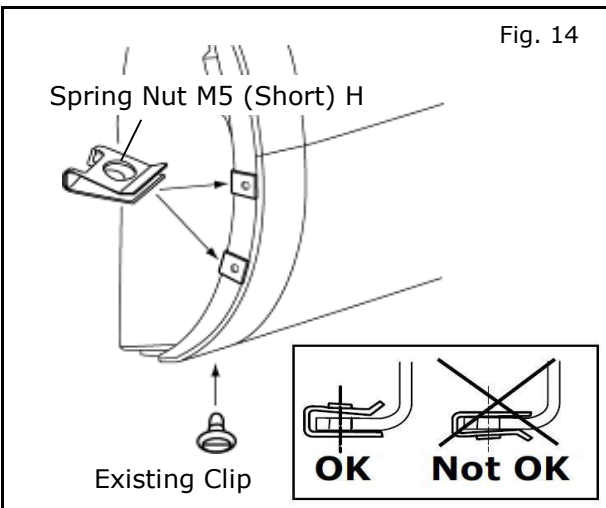

16) Install spring nut M5 (Short) H.
17) Reinstall existing clip to rear bumper.

Fig. 15

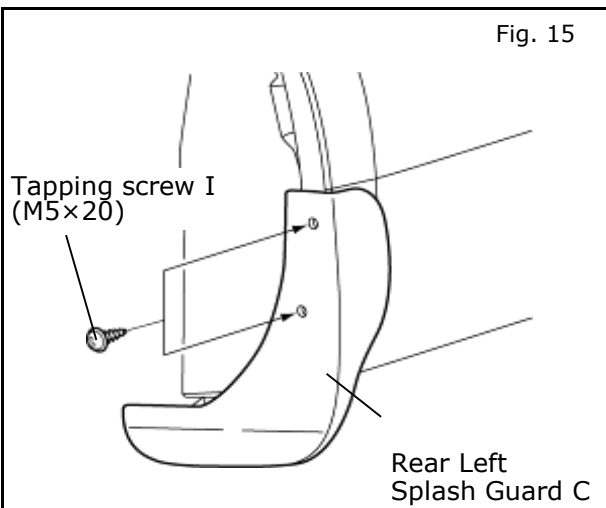

18) Align splash guard to vehicle and loosely install tapping screw I.

INSTALLATION PROCEDURE:

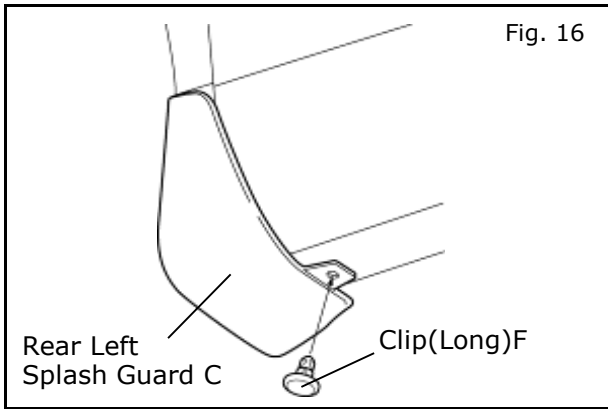

- 19) Install clip(long) F.
- 20) Repeat all steps for right side.

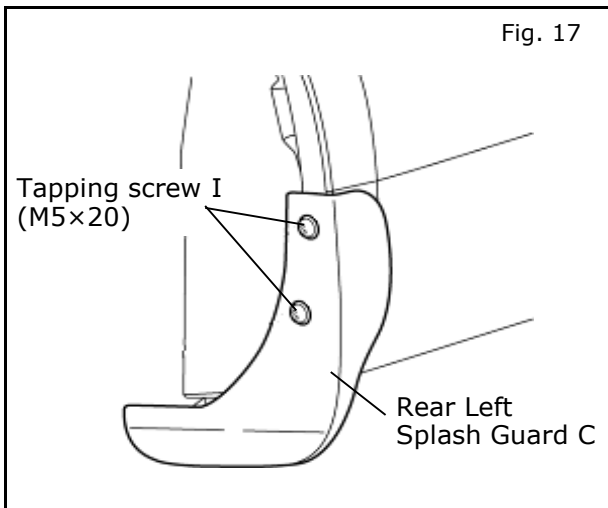

- 21) Tighten tapping screw I.

NOTE:

Hold Splash Guard tight to vehicle while tightening screws to ensure no gap occurs between Rear Bumper and Splash Guard.

Do not over tighten screws. Reference Tighten Torque: 3.8~4.4 N-m {34~39 in-lb}

If gap occurs between Rear Bumper and Splash Guard, remove Splash Guard and clips and check hole locations using templates (step 12). If necessary, re-drill holes to properly align with template and then reinstall Splash Guard starting with step 13.

FINAL INSPECTION

- Verify all clips are fully engaged and locked.